

## WGRQ45

### Triple Outdoor Drinking Fountain | Hi-Lo™



#### Specification

Manufactured from stainless steel including a stainless shielded bubbler with self-closing push button and non-squirt features. Valve includes flow adjuster and strainer. Integral perforated drain for hygiene & ease of cleaning. Smooth radiused design eliminates sharp corners. Fully concealed pipework and fixings. Unit is nonrefrigerated.

<b>Inlet Connection:</b>	G½B
<b>Outlet Connection:</b>	40mm BSP Waste
<b>Water Pressure:</b>	200 – 500 kPa
<b>Force To Activate:</b>	≤ 22N
<b>Basin:</b>	1.2mm, Type 304 Stainless Steel
<b>Housing:</b>	2.5mm, Type 304 Stainless Steel
<b>Finish:</b>	Enviro-Glaze® Fairway Green

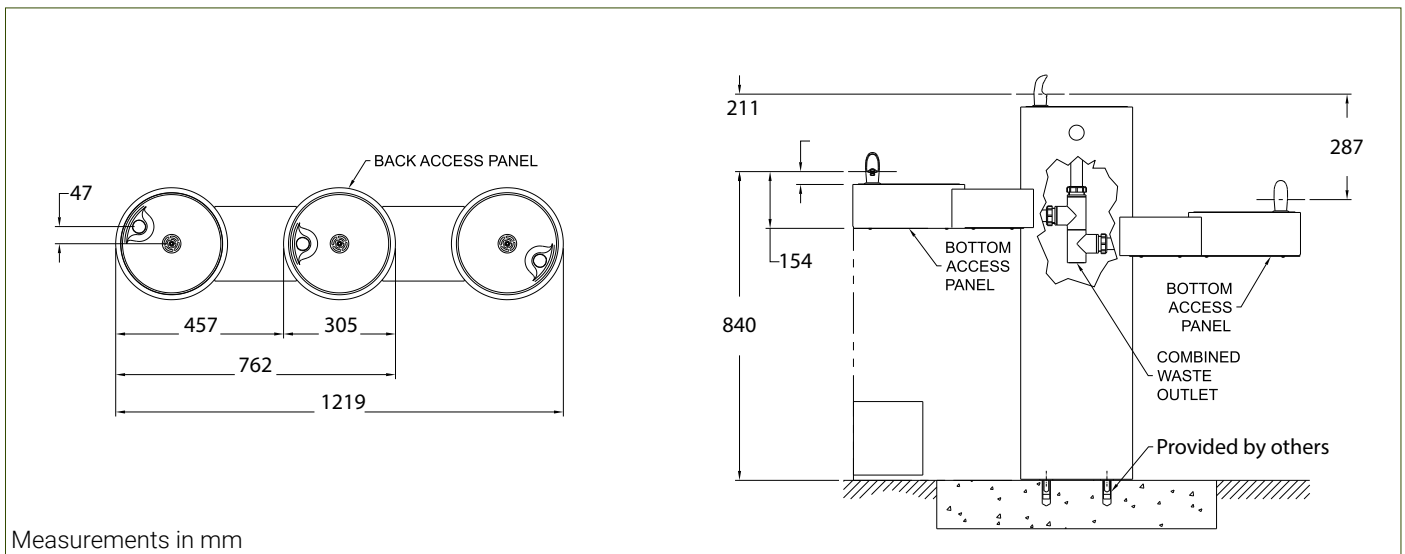

#### Resources

[Installation Guide](#) - [Warranty & Cleaning Guide](#) - [CAD Drawing](#)

As improvements in the design and performance of Bubblers Australia products are continuous, specifications may be subject to change without notice. The illustrations and descriptions herein are applicable to production as of the date of this Technical Data Sheet. Revised 08/23 © 2023 by Bubblers Australia TD/ModelWGRQ45/0823