



ABF16-BCD-IPL

H2O-to-Go!™ Bottle Filler, Sensor & Counter Display

Specification

Manufactured from #304 stainless steel with all exposed surfaces in satin finish and antibacterial impact resistant ABS surfaces. Sensor activated valve with strainer. Perforated drain for hygiene & ease of cleaning. Unit is non-refrigerated, but refrigerated options are available. Includes intuitive Bottle Counter Display to allow users to track the number of plastic bottles saved by choosing reusable containers. Suitable for indoor use only.

Inlet Connection:	G $\frac{1}{2}$ B
Outlet Connection:	40mm BSP Waste (P-Trap Included)
Water Pressure:	200 – 500 kPa
Water Temperature:	4 - 30°C
Flow Rate:	3.8 LPM Laminar Flow
Power Requirement:	9V (Transformer Included)

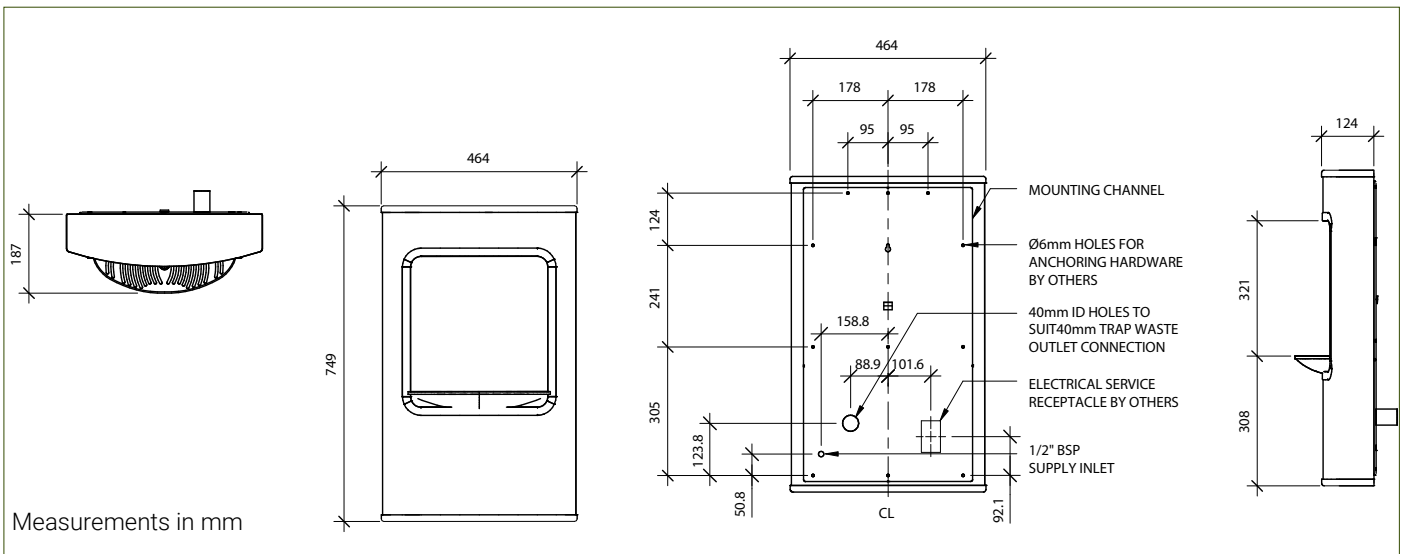

Resources

[Installation Guide](#) - [Warranty & Cleaning Guide](#) - [CAD Drawing](#)

As improvements in the design and performance of Bubblers Australia products are continuous, specifications may be subject to change without notice. The illustrations and descriptions herein are applicable to production as of the date of this Technical Data Sheet. Revised 08/23 © 2023 by Bubblers Australia TD/ModelABF16-BCD-IPL/0823