

A8909

Drinking Fountain Free Standing



Specification

Accessible Compliant to AS1428.2-1992. Manufactured from stainless steel with all exposed surfaces in satin finish. Stainless steel, shielded bubbler with self-closing, luminance contrast, push button and non-squirt features. Valve includes flow adjuster and strainer. Integral perforated drain for hygiene & ease of cleaning. Smooth radiused design eliminates sharp corners. Unit is not refrigerated and is suitable for outdoor use.

Inlet Connection:	G $\frac{1}{2}$ B
Outlet Connection:	40mm BSP waste
Water Pressure:	200 – 500 kPa
Water Temperature:	4 - 30°C
Basin and Housing:	1.6mm, type 304 Stainless Steel
Force to Activate:	< 20N

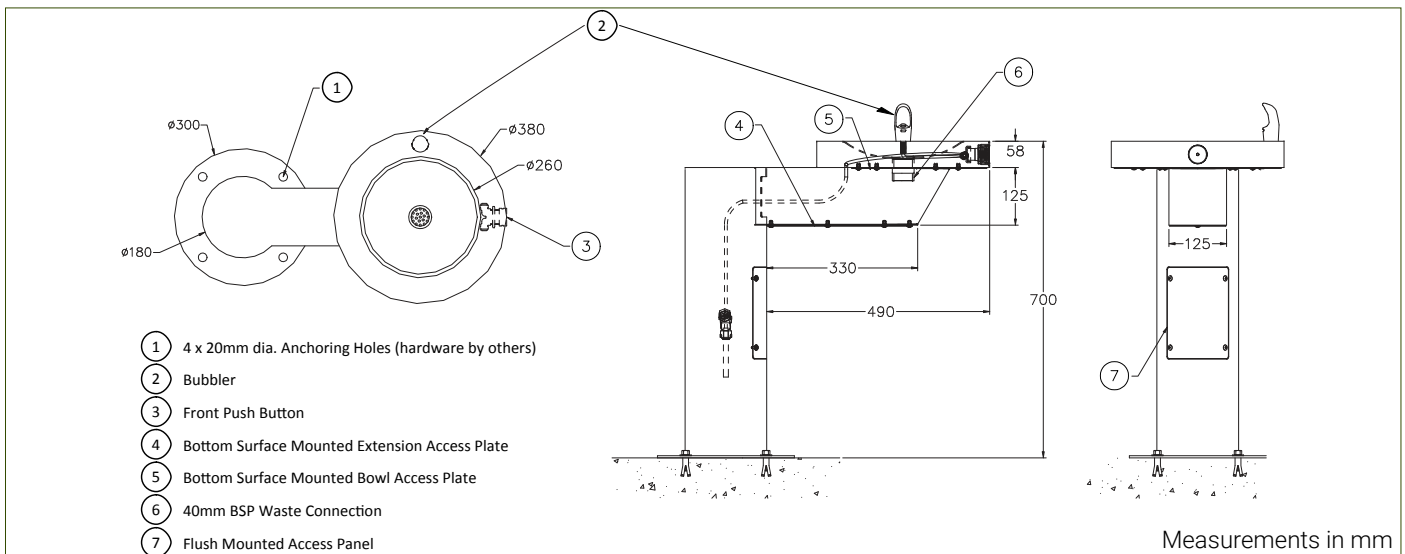

Resources

Installation Guide - Warranty & Cleaning Guide - CAD Drawing

As improvements in the design and performance of Bubblers Australia products are continuous, specifications may be subject to change without notice. The illustrations and descriptions herein are applicable to production as of the date of this Technical Data Sheet. Revised 08/23 © 2023 by Bubblers Australia TD/ModelA8909/0823